

NEWS 2023



A Z L I N E

AZLINE

The BRAND Identity

Our identity
it's consistency
between what we think
and what we make.

AZLINE is a constantly evolving reality, a seal of innovation in the home furnishing sector.

Synonymous with quality and excellence of Made in Italy, capable of transmitting the company's culture, dedication and know-how.

Our business stems from a global idea of the project, from A to Z, able to offer 360-degree professionalism, from architectural design to furnishing supply, thus founding our work in a synthesis of thought and achievements. We offer complete, warm and welcoming environments for the home, where the most innovative products dialogue with the unique design of the brand and with the excellence of craftsmanship. Every piece of furniture that comes from our ideas carries with it the imprint of Italian design, capable of making any space a place and filling it with being there.

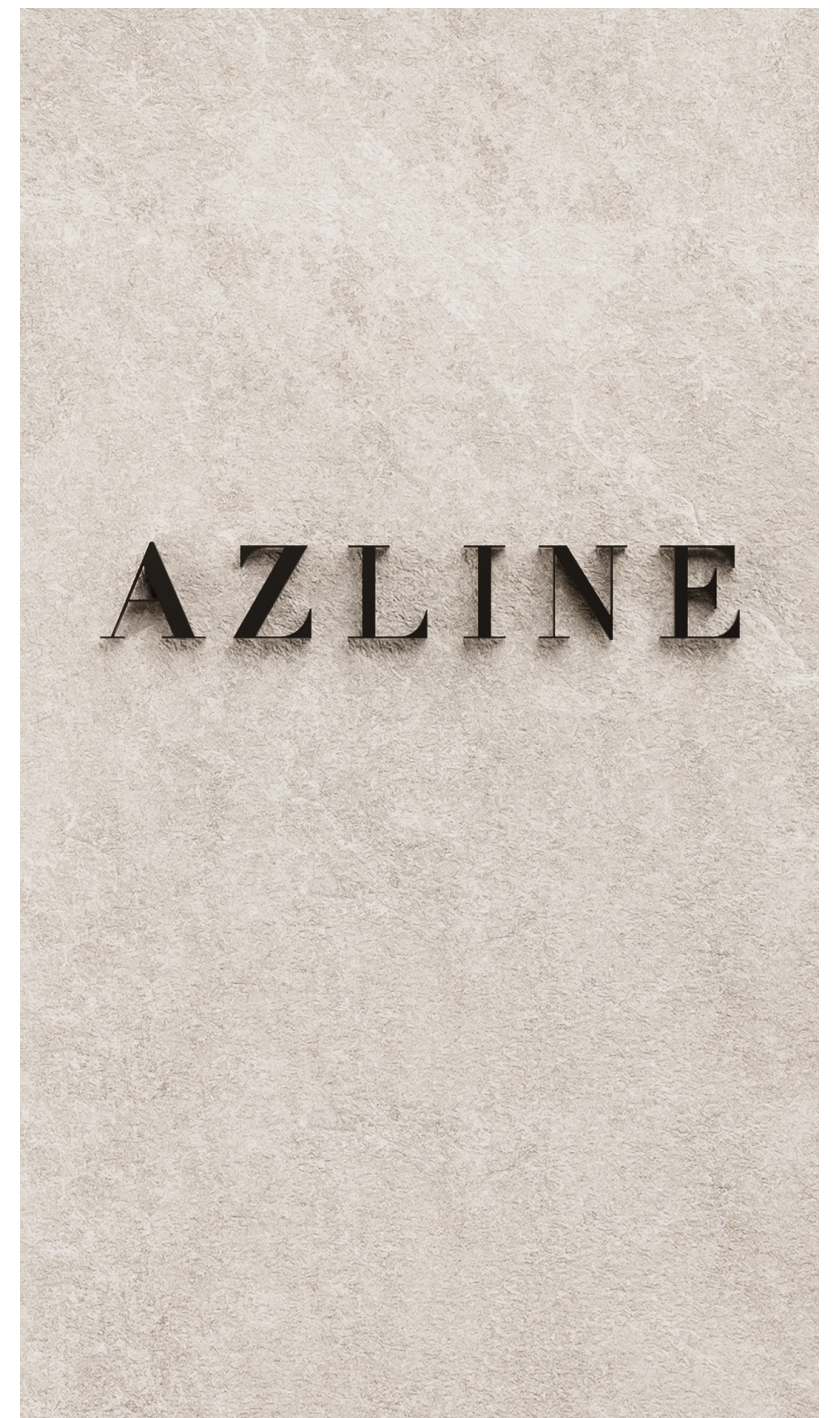

AZLINE'S *Mission*

Our goal is to create furniture for spaces functional, resistant and with a refined design for every style requirement.

Innovation and creativity are the indissoluble combination from which AZLINE furnishings are born, with the aim of creating furnishing supplies capable of transmitting and arousing emotions. "Our goal is to create functional, resistant interior furnishings with a refined design for every style requirement".

A taste that stands out for essential lines, harmonious

shades, refined materials and precious details, in the belief that the quality of the style generates timeless artefacts.

Creativity is limitless, the quality of the raw materials, already capable of conveying strong emotions, are enhanced by the attention to detail and the technological innovation of Made in Italy.

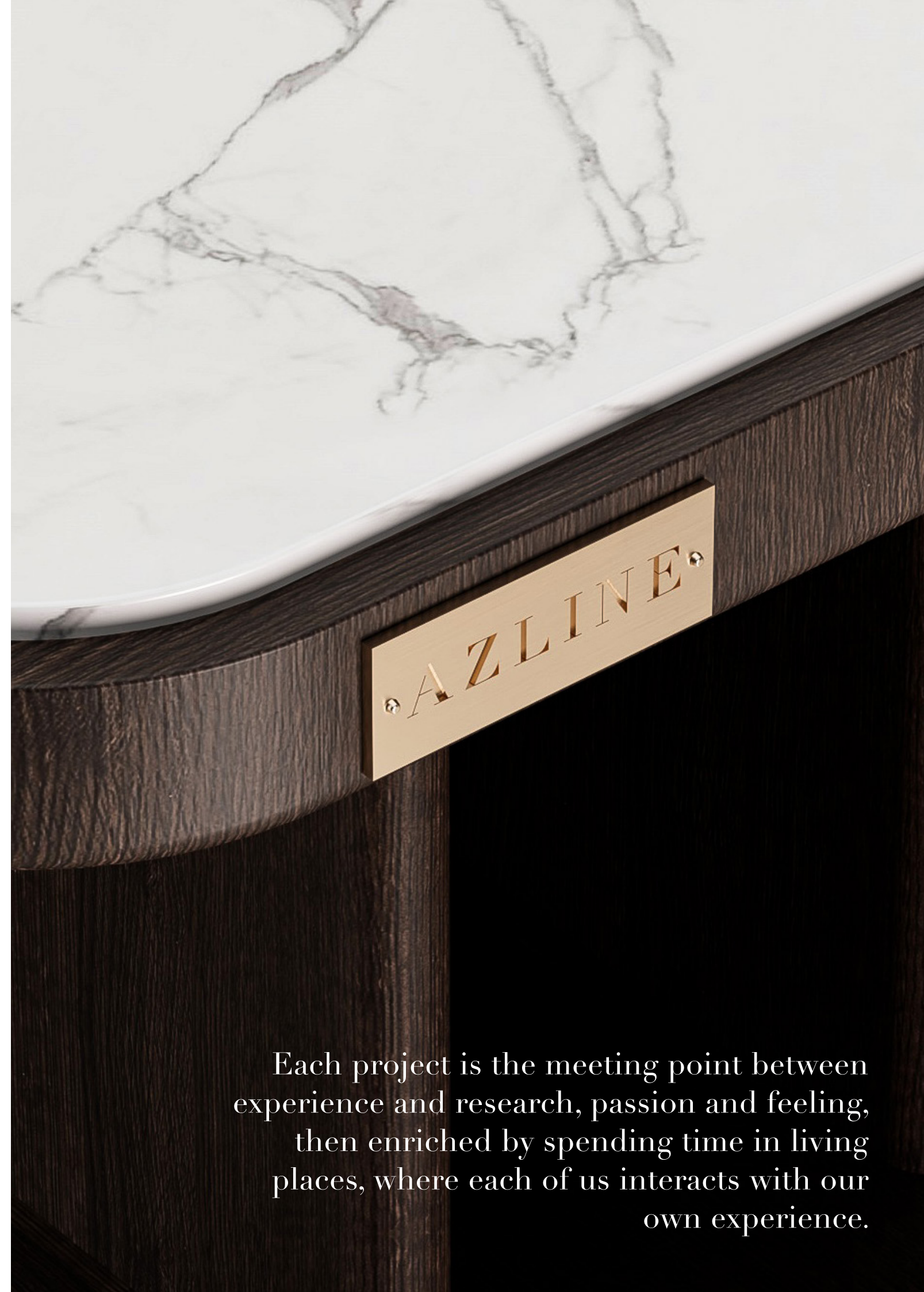

Each project is the meeting point between experience and research, passion and feeling, then enriched by spending time in living places, where each of us interacts with our own experience.



Synonymous with high class, refined elegance, refinement and luxury without ostentation. A stylistic project that encompasses furniture and architecture, in a continuous search for design development and innovation.

Space after space, a recognizable style emerges made of essential lines and balanced proportions, natural colors in harmony with refined materials and accurate details.

Nothing is left to chance but everything is part of a sensible space where quality and design are in perfect symbiosis.

This catalog expresses our indoor and outdoor novelties in a refined compositional and harmonious taste.

The RAYMONDE Table

A marked sculptural shape of the legs, reminiscent of stones smoothed by water, supports a marble top that gives it a strong austerity.

In this evocative, innovative context designed to convey dynamism, the original lines marry in perfect shape, giving a strong sense of harmonic movement. The meticulous attention to detail and the quality of the craftsmanship results in a balanced, unique and unrivaled product.

Details

Legs in Canaletto walnut completed with a white Calacatta marble top.

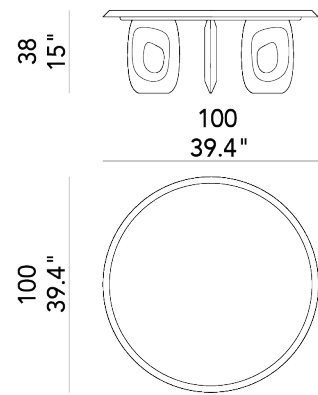

An open, bright and
convivial residence
where...

...beauty is in simplicity





In the relaxation area, the protagonists are the furnishings from the collection, a strong materiality stands out in the use of velvet, both for the carpet and for the upholstery of the Safari armchairs. The coffee table in Walnut and Calacatta marble it combines in an enchanting harmony with the context.

The SAFARI armchair

From the extraordinary design, in the name of sculptural language, this is how the Safari armchair was born. A solid structure in Canaletto walnut that tapers towards the top, supporting the backrest and the soft and comfortable seat.

Details

Structure in solid wood with polyurethane foam padding. Upholstery in various customizations including bouclè that combines wool and viscose in an irregular texture, mélange velvet in very fine cotton and pure wool with delicate mottling, contemporary-inspired wool canvas in the sign of an extreme richness of the material.

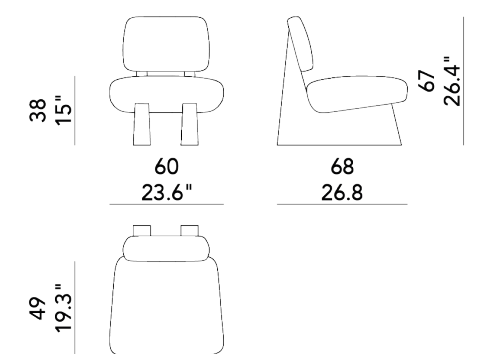

Fascinating perspectives make this project a charming living space that combines luxury and modernity embraced by the surrounding nature.

The JEAN bench



Designed as a transversal element for the sleeping area or the entrance area, the Jean bench stands out for its light and elegant materiality. The base of the seat, in wood, aligns with the uprights of the structure, a gesture that highlights the overall geometry of the project, bringing it back to the architectural linearity of this project. Two elegant roll cushions complete the search for a synthesis between timeless elegance and extreme modernity.

Details

Structure in solid Canaletto walnut with a moka-coloured oil-stained finish, Dedar Belsuede upholstery, a mottled velvet-effect chenille that evokes the comfort of leisure time and which, thanks to the weaving of the linen, takes on a characteristic mottled effect.



A villa, with an unprecedented harmonious balance, designed to immerse yourself in nature and escape from the convulsive rhythms of the city.

A convoy of spaces, with different uses, harmoniously enclosed with each other, make the environments organic and fluid, conveying the idea of passing through the trees of the surrounding forest. A structure that offers freedom and intimacy at the same time brings architecture and nature into dialogue, conceived in the philosophy of continuity. Thus was born the villa, characterized by a refined

rigor in the details, manifested in the selection of materials and furnishings. The texture of the wood defines the design of the ceiling which appears as a continuous surface: from the floor, it folds along the perimeter wall, finally becoming the ceiling, in an overall neutral and homogeneous effect. The thin aluminum profiles create a pleasant visual impact on the outside, creating attractive plays of light.

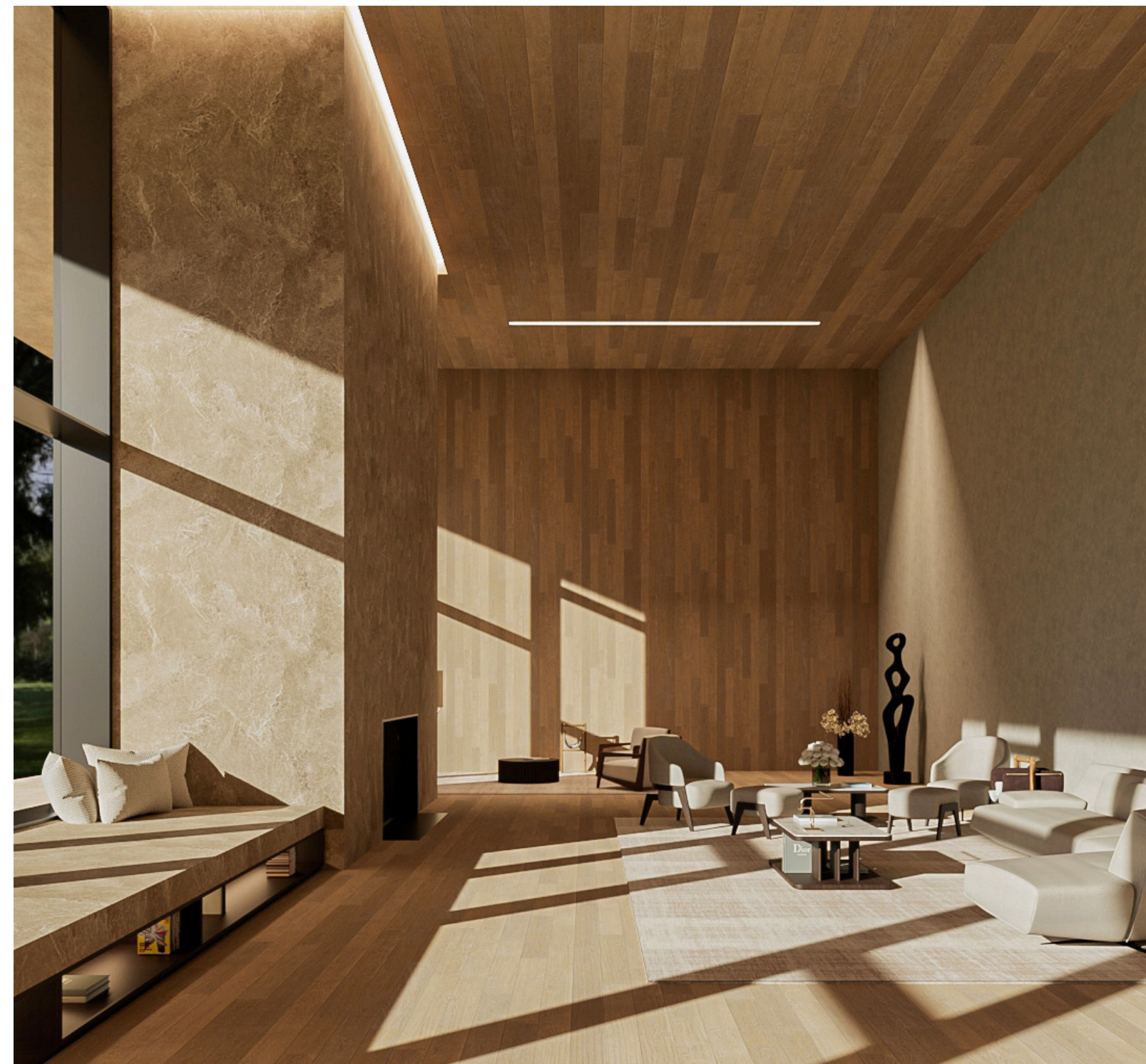

As nature commands

An evocative internal glimpse with the large double-height windows overlooking the outside.

In the living area, the furnishings are protagonists of the scene.

The QUATTRO table

Quattro was born from an idea of simplicity, severe proportions, the tactile value of wood combined with the elegance of marble. The aesthetic balance and rigorous balance of the individual components make it suitable for all rooms in the house. The Calacatta marble top, precisely framed by mocha-colored wood, gives an original touch thanks to its incredible chromatic nuances and veins.

Details

The structure in mocha-stained Canaletto walnut is embellished by the white Calacatta marble top.

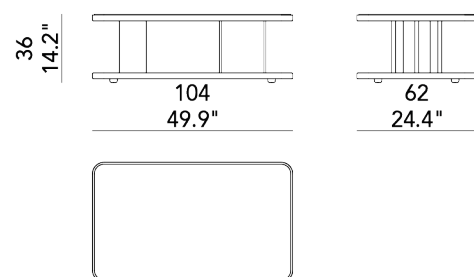

The JANETTE armchair

Janette wants to convey the elegance and grace of soft lines and generous volumes. The structure in solid walnut, with essential geometries, balances with the soft line of the backrest, to give life to a comfortable and refined seat also on a visual level.

The front legs in contact with the backrest completely envelop it, becoming part of it, thus leaving the rigid primordial geometry. Combined with the Horn pouf, which recalls the same lines. This modern style armchair allows for even greater relaxation.

Details

The structure in solid Canaletto walnut is embellished with the padding in high capacity polyurethane foam, covered with a soft full-bodied natural-coloured wool twill.

A textural and irregular twill that combines a linen warp with a bouclé wool weft.

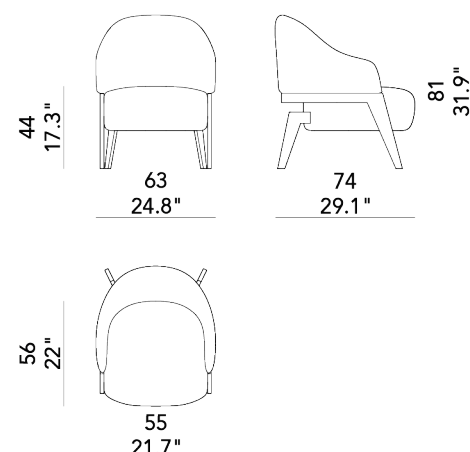

Between simplicity and modernity, purity of lines and materiality of textures, natural colors and bright accents.

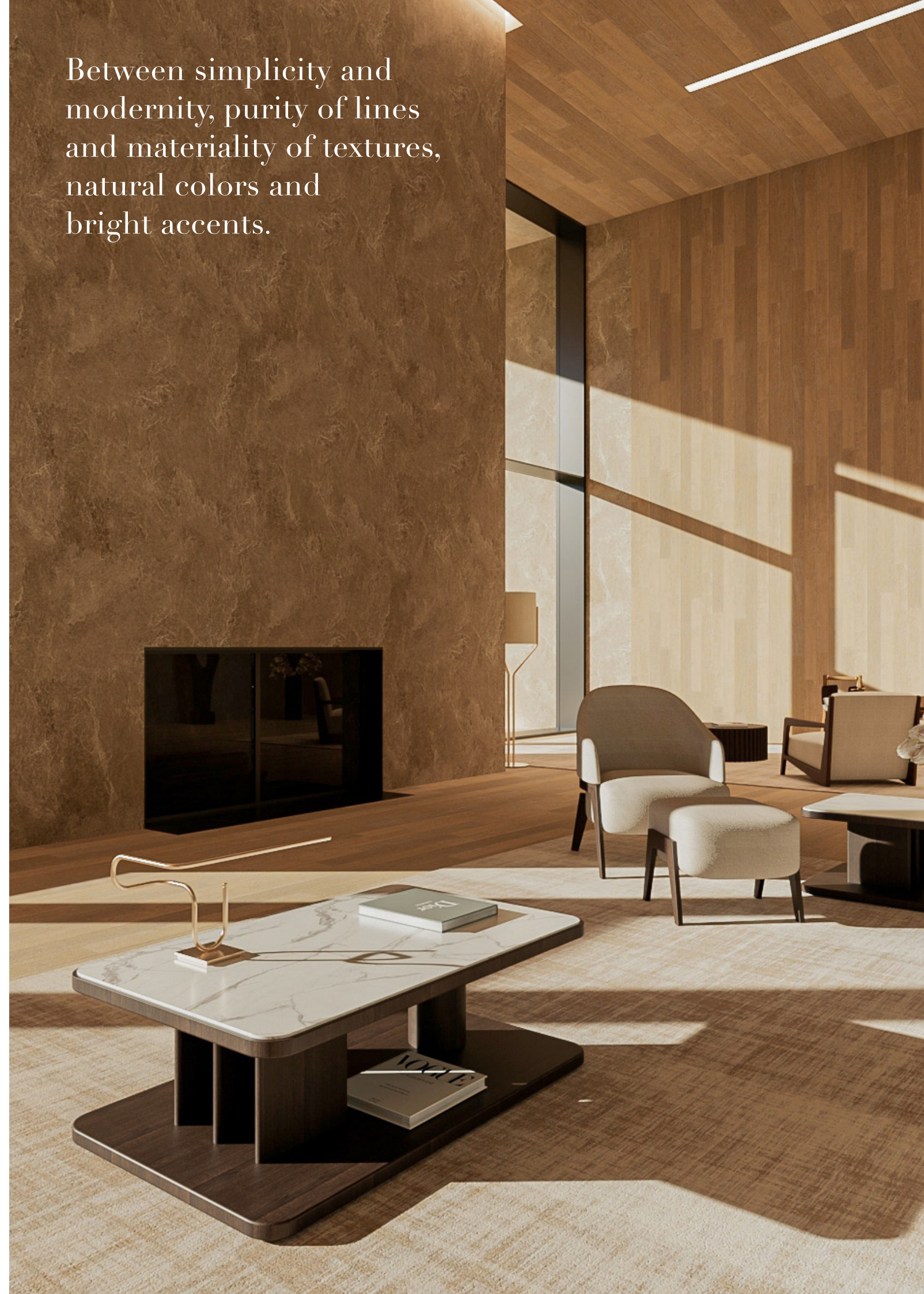

The
ETIENNE
chair



The Etienne chair expresses the perfect combination between the balance of symmetry and the comfort of shapes, becoming at the same time a functional chair and a domestic sculpture. The lines of the backrest with an enveloping silhouette bend to become the same front support legs. The tapered vertical elements, in a system of rhythmic lines and spreads, are specifically designed to acquire stability, finally connected by the seat.

Details

Structure in solid Canaletto Walnut with a moka oil-stained finish, Dedar Belsuede upholstery, a mottled velvet-like chenille that evokes the comfort of leisurewear and which, thanks to the linen weave, takes on a characteristic mottled effect.



A palette that blends the colors of the landscape and natural materials enclosed in the philosophy of simplicity.

The MEA NUI Table

With an original and recognizable aesthetic, a true tribute to nature, the Mea Nui coffee table completely in wood tells the strength of the material. The workmanship of the structure is inspired by the art of cabinet-making, a detail that is much more than an aesthetic choice and tells the company's care, attention and know-how. A transversal piece of furniture, which adopts the philosophy of "less is more", therefore inspired by the concept of essentiality.

Details

Oil-stained Canaletto Walnut wood.

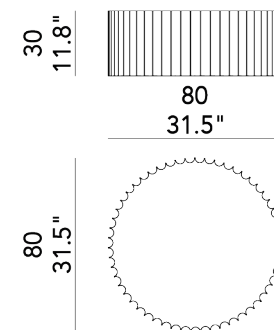

A relaxation area cut out at the end of this large living room, furnished with the Nova armchairs and the Mea Nui coffee table in walnut in a perfectly balanced dialogue.

Not just feeling...

The strength of the landscape, the wonderful panorama of the hills and fascinating perspectives make this project an enchanting living space. Thus the panorama becomes the protagonist of the scene and at the same time an antagonist together with the interiors. Natural materials such as wood and travertine walls instill warmth and harmonious

and relaxing chromatic notes. The quality of this interior arises precisely from the ability to make the design pieces, with different characters and functions, dialogue with the enveloping surrounding landscape. The outside enters the inside and vice versa, generating a system of sophisticated continuity.



An architecture rich in details and materials chosen in close correlation with the furnishings in a balanced result where nothing is left to chance.

The design pieces are signed AZLINE, the protagonist of the living space is the Aryan table in Italian travertine combined with the Marseille chairs with soft and enveloping lines. In the relaxation area, two Sullivan armchairs with a strong formal meaning complete the space, giving a solid touch to the composition.



The juxtaposition of full elements covered in travertine and glass elements creates the perfect rhythm to fully enjoy this interior space.

The
ARYAN
table

A table with generous dimensions, where soft lines and details of great visual strength meet, such as the support of the travertine top on the legs, the result of a skilful play of angles.

The sophisticated alignments symbolize an overall and balanced continuity and the combination of two materials of the same nature gives a unique personification.

The close relationship between furniture design and architecture, evoked in the use of supports as pillars, bears witness to the sense of solidity and the great craftsmanship in woodworking.

Details

The legs in oil-stained Canaletto walnut are completed with a support surface in Italian travertine with a shaped profile specifically designed to adapt to vertical supports.

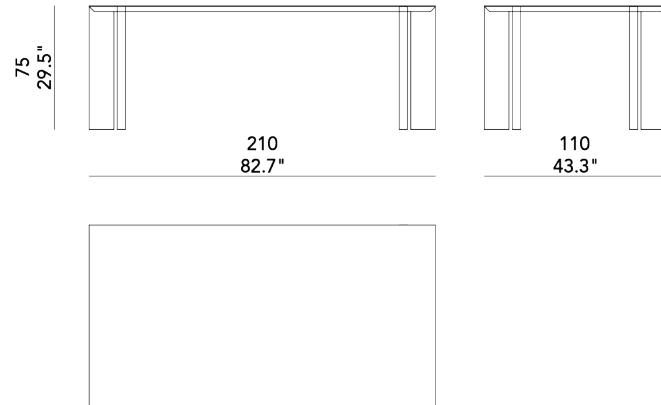

The
MARSEILLE
chair

Marseille represents the perfect completion of all the tables thanks to the soft and continuous stretch of the shapes. The solid wood structure envelops the seat and appears to be supportive to the comfortable backrest. Careful attention to proportions, connecting angles and thicknesses make this chair unique and capable of summarizing architecture with maximum comfort and hospitality.

Details

Solid structure in solid Canaletto walnut. Upholstery Dedar Dante, a mélange velvet in very fine cotton and pure wool that is soft, comfortable, full-bodied and compact.

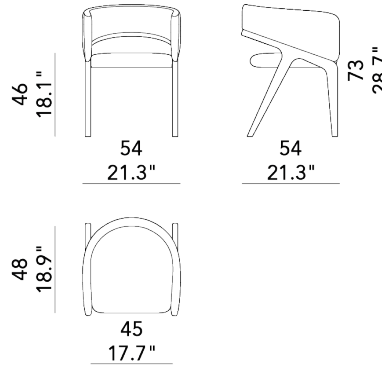

A play of light and shadow



A living room that blends into the landscape.

The SULLIVAN armchair

Sullivan is the result of experimentation and skilful dialogue between balance and elegance of curved lines combined with the rigidity of geometric lines. Designed for elegant day and night environments in which to carve out spaces dedicated to unparalleled comfort and intimacy. Comfortable cushions take up the geometric lines of the upper part, integrating perfectly into the complexity of the composition.

Details

Solid structure in Canaletto Walnut. The cushions are covered with a material weaving signed Dedar, it is a full-bodied weave between the materiality of the linen yarn and the sheen of the viscose, in vibrant chromatic variations.

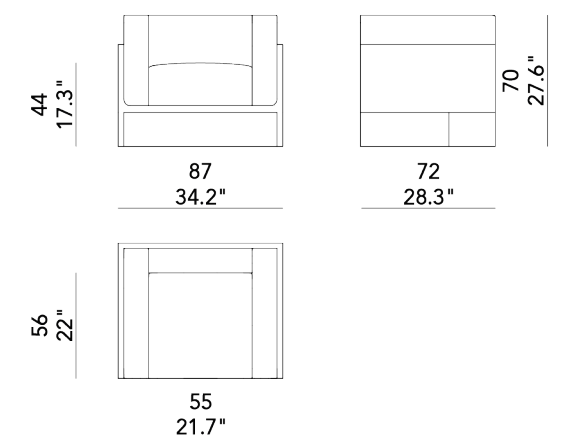

An intimate and convivial space on staggered levels, this living room is embellished by the Sullivan armchairs and the Odlo coffee table which recalls the finishes of the wall bookcase.



The ODLO Table

Odlo is a complement with a contemporary, elegant and refined design, a vigorous piece for any classy living room. The structure in thin wooden slats creates a rhythm of solids and voids and embellishes the marble and brass finishes in a visually harmonious triad. The gold shades of the marble evoke the finish of the brass base, creating an intriguing chromatic continuity.

Details

Structure in mocha-colored oil-stained Canaletto walnut.
Table top in Calacatta marble with gold reflections.
Base finish in brushed brass.

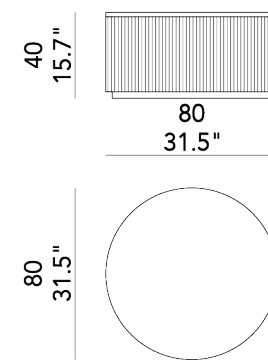

A living room capable of combining modernity and timeless style.



The NOVA armchair

Elegant modern language with an innovative touch, the Nova armchair is synonymous with design capable of harmoniously enriching the environment in which it is placed.

The essential design of the structure underlines the naturalness of solid wood and combines with attention to comfort; the seat and backrest are in fact completed by soft padding of variable density.

Details

The Canaletto Walnut solid wood structure is embellished with high capacity polyurethane foam padding, covered with a soft wool Bouclé by Dedar Milano that combines wool and viscose in an irregular texture inspired by the precious astrakhan furs. A fabric with a soft and full-bodied hand.

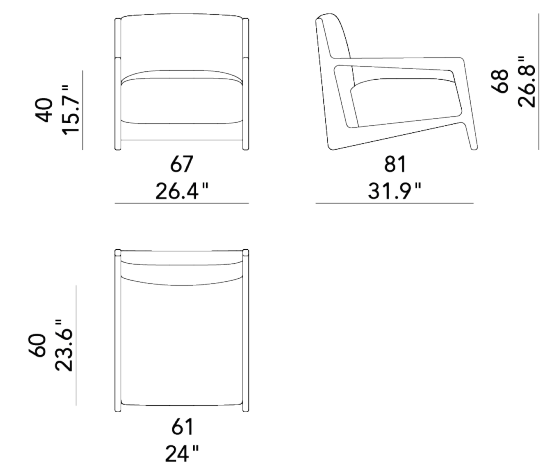

Complements capable of integrating with the architecture, linked by a unique aesthetic and unparalleled elegance.

The EZRA chair

Expression of the value of craftsmanship, the Ezra chair conveys the absolute quality of the details performed with care and passion. Designed to adapt to any space and circumstance thanks to the fluid lines of the backrest, it is capable of blending ergonomics and elegance to create a refined and comfortable product.

The thin legs in solid Walnut wood recall the soft lines of the padding, eliminating any rigid corner. The base of the seat is centrally supported by the legs to make it visually lighter, almost suspended.

Details

Structure in solid Canaletto Walnut wood. Dedar Dante upholstery, a mélange velvet in very fine cotton and pure wool. Soft, comfortable, full-bodied and compact.

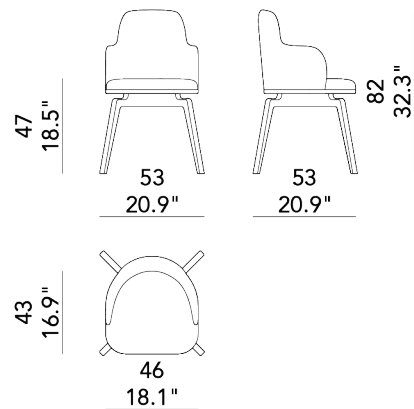

Minimal design to caress
with the eyes, tactile
surfaces to feel on the
skin.

The OLEA Table

Ole A, a strong intrinsic harmony of rigidity, sensuality and naturalness is affirmed in the choice of the combination of marble and wood. The legs with a tenacious communicative force, purely geometric, are embellished by the Italian marble top, inserted in a linear sculptural complex with a strong material contrast.

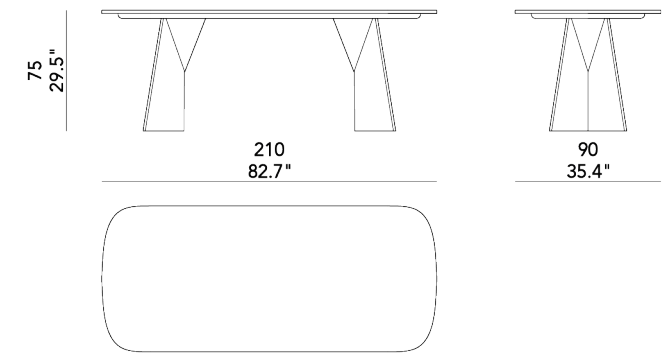

Details

Structure in moka-colored oil-stained Canaletto walnut.
Top in Italian Calacatta marble with golden reflections.





A large room with a 180-degree view of the rocky promontories that surround this villa in open nature. Large columns, covered in dark stone, give rhythm to the play of light, creating a strong contrast with full voids on the south facade.

The OUTDOOR collection

The new Outdoor proposal draws inspiration from the exclusivity of Italian excellence, sought after and refined using only Teak wood.

The collection has the same peculiarities as the indoor collections: class, refined elegance, refinement and timeless design.



The collection comes from essential woodworking, with a design capable of interpreting traditional wisdom and craftsmanship, in a contemporary aesthetic language. The seat cushions are inserted in a Teak wood structure. The proportions and clean lines of the cladding accentuate the refined beauty of the wood. The cushions are generously thick to emphasize comfort and the presence of the material.

The LAURENCE *armchair*

A skilful play of angles and lines creates a perfect balance, where teak wood marries with fabrics with fine finishes.

Under the banner of contemporary and essential elegance, the expertly designed silhouette translates into unparalleled comfort. A singular design piece, created to be placed outdoors for the nautical world, or by the pool.

Details

Teak wood is completed with comfortable padding covered with a material and full-bodied twill brings the exuberance of the material and yarns to the fore. Fireproof, washable and resistant to abrasion, atmospheric agents, sunlight and mould. It combines the richness of the material with attention to the environment, thanks to the composition in recycled yarn which makes it possible to reduce the consumption of virgin raw materials.

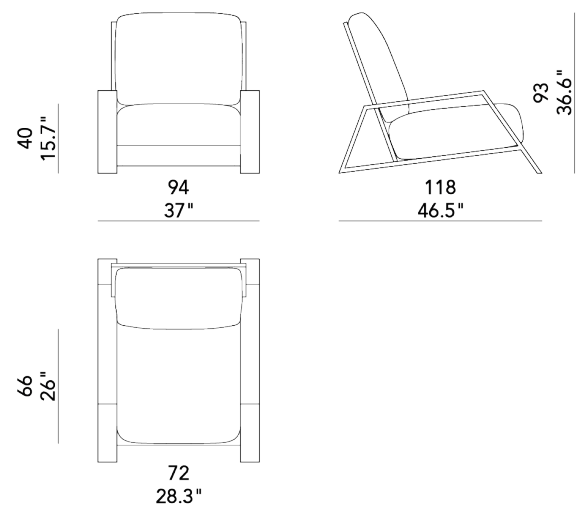

Solid teak wood with a linear and harmonious design. The collection expresses the characteristics of the materials and the comfort of the design in an unrivaled charm.

Totality:
Architecture, Nature,
proximity to the sea and
the mountains.



The MATHIEU *sofa*



Mathieu reflects the stylistic canons of the collection and, together with the Laurence armchair, completes the elegant and innovative outdoor seating set. Linearity and harmony of shapes are the cornerstones of the sofa's natural elegance. Comfortable outdoor cushions, with carefully chosen finishes, such as to elevate the general appearance, emphasize a sense of functionality and hospitality.

Details

Teak wood structure suitable for external conditions, the upholstery of the padded cushions is combined with the Laurence armchair, it is made of a fireproof, washable and resistant material and full-bodied twill.

The BAIA table

To complete the outdoor set, Baia, a practical table entirely in teak wood. It takes up the aesthetic motifs of the collection, such as linear strength and primitive forms in the name of architectural design, purely essential and geometric.

Details

Completely in Teak wood.

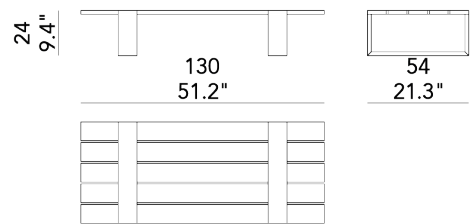

The light union of
design and nature.

A Z L I N E

T +39 3468520169

info@azline.co

www.azline.co

AZLINE realizes all its collection in Italy using selected components and raw materials made in Italy.

AZLINE reserves the right to make, without notice, any modification aimed at the functional and qualitative improvement of its products. Texts and drawings in this brochure are for informational purposes: for all technical and dimensional aspects, refer to the website www.azline.co and relative updates. The color and material samples are indicative.

A Z L I N E | online store



@azline.co



@azline.co



azline_co

**Know How, quality and work ethics are the pillars
on which our philosophy is based and from which
our products derive.**